

MotorGuide REPAIR PARTS

Model:
TE109VP

SPECIFICATIONS:

Year of Intro 2001
 Thrust 109LBS
 Volts 36VDC
 Amp Draw ~ 0 to 48amps
 Std. Mount 21 Gator II
 Speeds Infinite Variable

PARTS ORDERING & TECH ASSISTANCE

Consumer Relations
 Phone 800-841-2738
 Fax 800-982-8093

RETURNING GOODS

Returned Goods must be accompanied with a Returned Goods Authorization. Contact MotorGuide Consumer Relations to obtain RGA.

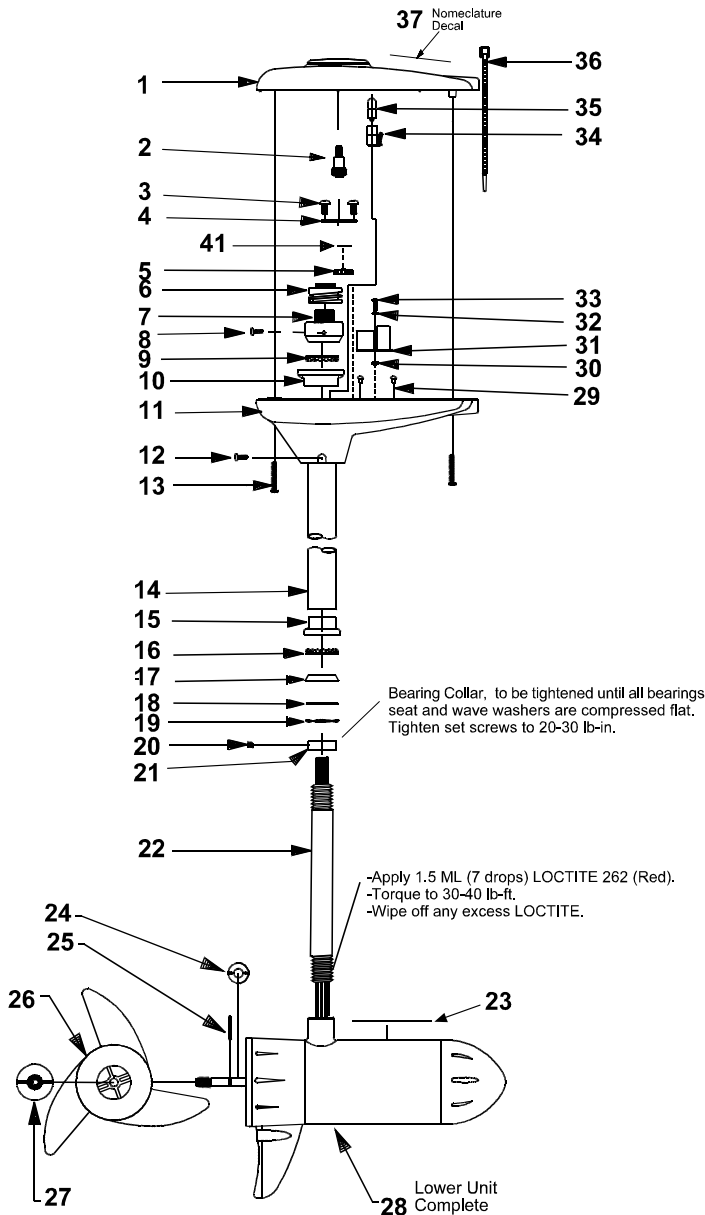

KEY	DESCRIPTION	PART #	KEY	DESCRIPTION	PART #
1	TOP HOUSING COVER ASY	AF053-16	25	PROP PIN	BR102-02
2	INDICATOR GEAR	AF069-02	26	PROP	AF124-12
3	SCREW SS	BK136-02	27	PROP NUT	AR099-01
4	BRACKET ASY	AF3155-01	28	LOWER UNIT	XS397-02
5	IDLER GEAR	AF069-03	29	STEM BUMPER	FM023-01
6	CABLE DRUM	FM067-01	30	WASHER	FM171-02
7	DRUM COUPLING	FM064-02	31	36 VOLT DURA AMP BOARD	AF157-05
8	SCREW 0133-20	FM133-01	32	WASHER #4	FM098-01
9	BEARING	FM005-01	33	4x5/16 SELF TAPPING SCREW	XT141-01
10	RETAINER/BEARING CUP	FM007-01	34	LAMP HOLDER ASY	AF394-01
11	TOP HOUSING BASE	AF004-11	35	LAMP	AF093-01
12	1/8 X 3/8 RIVET	LF111-03	36	CABLE TIE	AF030-01
13	SCREW #10X24X.75	AF141-02	37	NOMENCLATURE	AP056-19
14	OUTER TUBE	AF165-06			
15	RETAINER/BEARING CUP	FM007-01			
16	BEARING	FM005-01			
17	BEARING RACE	AF006-03			
18	O RING	AF063-01			
19	WAVE SPRING WASHER	AF171-01			
20	CONE SET SCREW	AF143-01			
21	BEARING COLLAR	XF006-01			
22	COLUMN 42"	FM049-05			
	COLUMN 50"	FM049-08			
23	DECAL	AF060-05			
24	MONOFILAMENT WASHER	AR175-01			

Model:
TE109VP

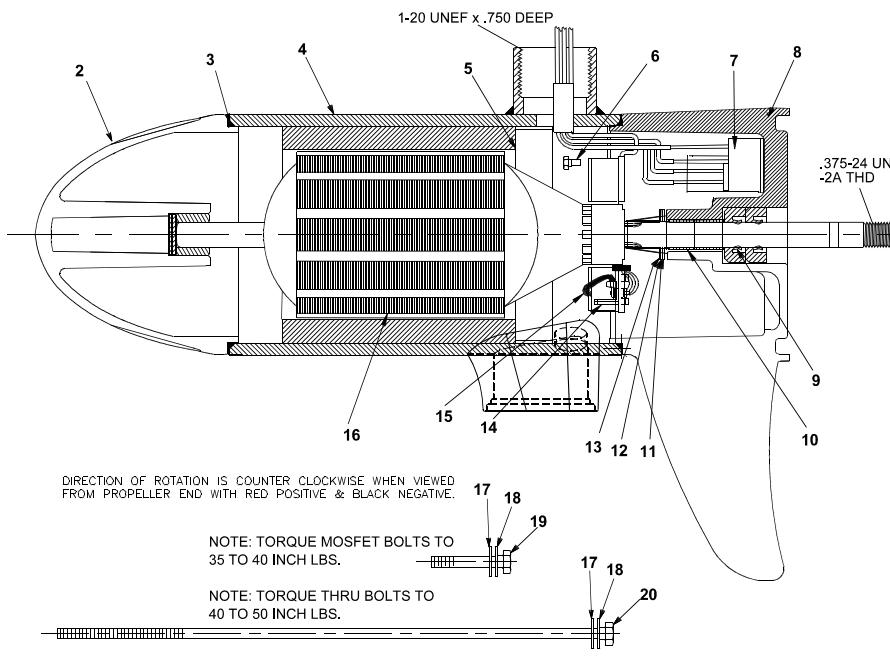

KEY	QTY	DESCRIPTION	PART NO.
1	X	MOTOR	XS397-02
2	1	NOSE CAP	XF3212-01
3	2	O RING SEAL	MR217-01
4	1	HOUSING ASY	XS3210-03
5			
6	2	BRUSH CARD SCREW	MR228-01
7	1	DURA AMP MODULE	JF096-11
8	1	COMM CAP	XS3205-02
9	2	SHAFT SEAL	MR223-01
10	1	BEARING	MR206-01
11	1	NYLATRON WASHER	MR226-01
12	1	WASHER	MR227-01
13	1	E RING	MR219-02
14	2	BRUSH SPRINGS	MR214-02
15	1	BRUSH ASY LESS SPRING	XS3201-02
16	1	ARMATURE	XF3207-01
17	4	STATIC SEAL	MR222-01
18	4	THRU BOLT WASHER	MR216-02
19	2	DURA AMP SCREW	MR229-04
20	2	THRU BOLT	MR218-18
**	1	ARROW DECAL, TEAL	XS060-01

DIRECTION OF ROTATION IS COUNTER CLOCKWISE WHEN VIEWED FROM PROPELLER END WITH RED POSITIVE & BLACK NEGATIVE.

NOTE: TORQUE MOSFET BOLTS TO 35 TO 40 INCH LBS.

NOTE: TORQUE THRU BOLTS TO 40 TO 50 INCH LBS.

WIRING

GEAR ADJUSTMENT

LOOSLY INSTALL TWO MOUNTING SCREWS ADJUST BRACKET/GEAR ASSY FOR BEST TOOTH ENGAGEMENT TORQUE BOTH MOUNTING SCREWS TO 18-20 IN/LB

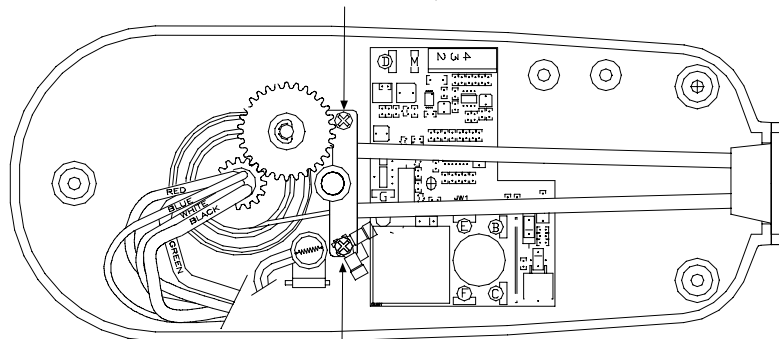

Connect white wires from pedal and/ or motor and/or transducer cable here.

SUBJECT TO DAMAGE BY STATIC ELECTRICITY ASSEMBLE AT STATIC FREE WORK STATION!

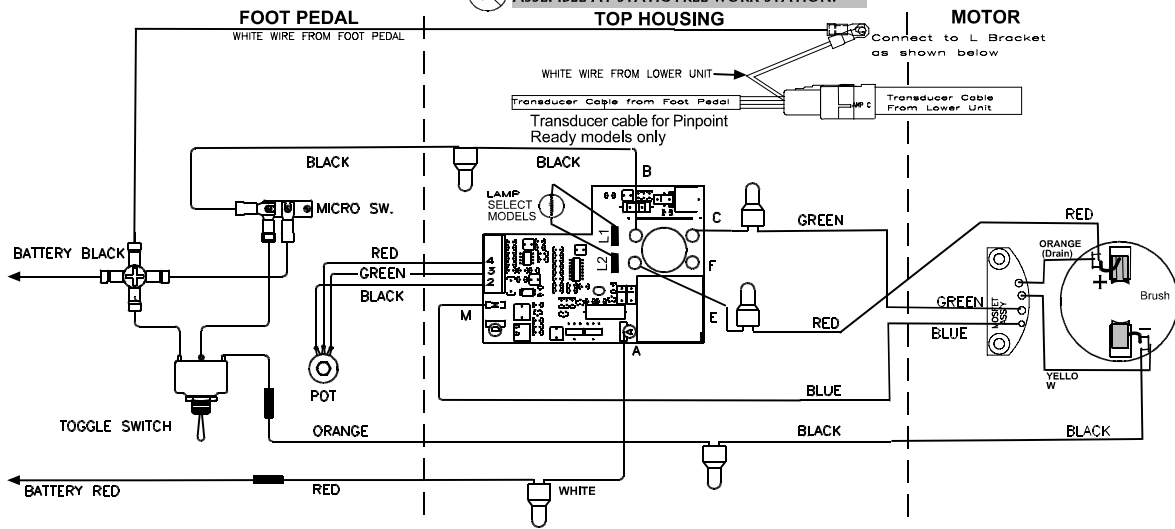

**(BLACK) TOUR EDITION
VARIABLE SPEED PEDAL ASSY**

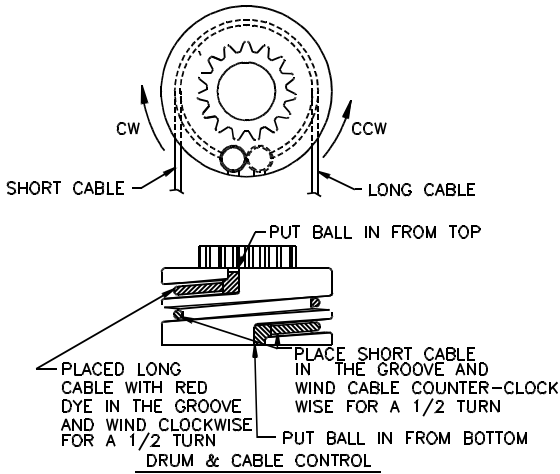

NOTE: APPLY CABLE TO DRUM CONTROL BEFORE PUSHING THE DRUM CONTROL ON THE DRUM COUPLING

ITEM #	DESCRIPTION	PART #
1	SCREW	FM133-04
2	PULLEY	PM121-01
3	PIVOT-PULLEY	PM122-01
4	NUT-.312-24 SS	PM098-02
5	SPRING COMPRESSION	PM014-01
6	E RING	BK046-01
7	PIN - FOOT PEDAL	PM102-01
8	THOMPSON BUSHING	AP020-01
9	CABLE CLAMP	AP036-01
10	SCREW 10-32X.38PH	FM133-03
11	TERMINAL BLOCK	PM187-01
12	PEDAL BASE	PM003-01
13	CABLE TIE	AF030-01
14	MICRO SWITCH	AP151-01
15	6-32 NUT SS	SP098-02
16	SCREW #6X32X1.12	PM135-01
17	TOGGLE SWITCH	PM3153-01
18	SWITCH BOOT	FP177-01
19	POTENTIOMETER	AP168-01
20	NUT PUSH ON	PM046-01
21	ROTARY KNOB VARIABLE	PM082-01
22	FOOT PEDAL	PM101-03
23	DECAL	PM057-03
24	COVER, SWITCH	PM026-01
25	MICRO SWITCH BOOT	KP157-01
26	PAD, FOOT PLATE	PM054-01
27	BATTERY CABLE	PM328-02
28	GROMMET	AP071-01
29	STEERING CABLE SHORT FOR 60"	PM027-01
30	STEERING CABLE LONG FOR 60"	PM027-02
31	STEERING CABLE SHORT FOR 72"	PM027-03
32	STEERING CABLE LONG FOR 72"	PM027-04
31	10-12 FLAG TERMINAL	BR161-01
32	INSULATOR SLEEVE	AT080-01

